



OREGON DOCUMENTS

JUL 5 1983

LIBRARY OF PORTLAND

1983 PORTLAND ROSE FESTIVAL MILK CARTON BOAT RACES

Sunday, June 5, 1983
Westmoreland Park Casting Pool
S.E. McLoughlin at Bybee

Skipper's®

SAFETY

To insure a fun and safe event, the following safety regulations will be enforced:

1. A U.S. Coast Guard approved life jacket or vest should be worn by each participant at all times while on the water during testing and competition. Failure to do so will result in the disqualification of the entry.
2. Any boat judged to be unsafe or unqualified will not be allowed to compete in the race and will not be allowed on the water.
3. Races will be run by classification on a designated race course. Only boats qualified for each classification will be allowed on the water after the races have begun.
4. Disposal of boats is the responsibility of the participant. To save your boat it **MUST** be claimed and removed immediately following your race. For safety it cannot be left at the finish line or in the launch areas.
5. Remember each ½ gallon container will float 4 pounds, each gallon container 8 pounds. Be sure to allow for both the weight of the crew and the boat.

GENERAL RULES

1. All boats shall not exceed 12 feet in length and shall use resealed half-gallon or gallon paper milk cartons for primary flotation. Styrofoam, balloons, inner tubes, tanks or other materials or devices for flotation will not be allowed. Plastic wrap is prohibited; cartons must be in contact with the water.
2. Milk cartons can be resealed by stapling, taping, hot glue, and/or a combination of these.
3. All entries must be received by May 27, 1983, at the Rose Festival Association office. Participants must register and have their boat inspected on race day. No boat will be allowed on the water for competition until inspection is completed.
4. Each race classification will be divided into race heats established by the total number of entrants.
5. First, second, third and fourth place winners in each race will be determined on the basis of "best times" from ALL heats of that race.
6. A boat may compete in only one of the manpowered racing events (i.e. races 1 through 3). No matter if the crew changes, the same boat may compete in any or all of races 4 through 7.
7. Showboat category entries shall be capable of navigating the waterway under their own power. Judges will select the showboat winners on the basis of creative design and originality.
8. Removal of the boats from Westmoreland Park at the end of the races is the responsibility of all entrants. Please do not litter.
9. Boat races are open to all boys and girls for ages 8 through 16, plus parents in race No. 6 and members of the media in race No. 7.
10. Manpowered racing boats entered in races 1, 2, 3, 5, 6 and 7 may be propelled by paddles or oars only. No engines or motors of any type may be used. Participants must remain aboard the boat at all times and use of hands or feet to propel the boat is not permitted.
11. Sailboats entered in race No. 4 must be totally wind propelled while racing. Any size or type of sail may be used, but oars, paddles, motors, engines, hands, or feet may not be used. The tiller cannot be used to propel the boat. Participants must remain aboard the boat at all times.
12. Infraction of any of the above rules will mean disqualification of boat and crew. ALL DECISIONS OF THE RULES-COMMITTEE AND RACE REFEREE WILL BE FINAL.

THE RACES

Sunday, June 5, 1983

Registration starts at 12:00 noon

RACE #	CLASS	AGE	STARTING TIME
1	Manpowered racing boats	8-10	1:00 p.m.
2	Manpowered racing boats	11-13	1:30 p.m.
3	Manpowered racing boats	14-16	2:00 p.m.
4	Sailboats	8-16	2:30 p.m.
5	Showboats	8-16	3:00 p.m.
6	Parents Fun Race	Parents	3:30 p.m.
7	Media Race	Open	4:00 p.m.

The 11th Annual Milk Carton Boat Races are sponsored by:

Skipper's Seafood and Chowder House

The Portland Rose Festival Association

Guest M.C.: Craig Walker of 62 KGW

RACE COURSE LOCATION

Westmoreland Park is located adjacent to S.E. McLoughlin Boulevard at 7700 S.E. 22nd. The races will be held in the Westmoreland Park Casting Pool. Please use parking lots on 22nd Street rather than park on S.E. McLoughlin Boulevard. For further information or answers to questions regarding the boat races, please contact the Rose Festival Association at 227-2681.



PRIZES

All participants will receive a free Skipper's Regular Fish Dinner.

All First, Second, Third and Fourth place finishers will receive a trophy for their efforts.

All races except No. 6 and No. 7 offer these cash awards:

First Prize \$50

Second Prize \$25

Third Prize \$15

Fourth Prize \$10

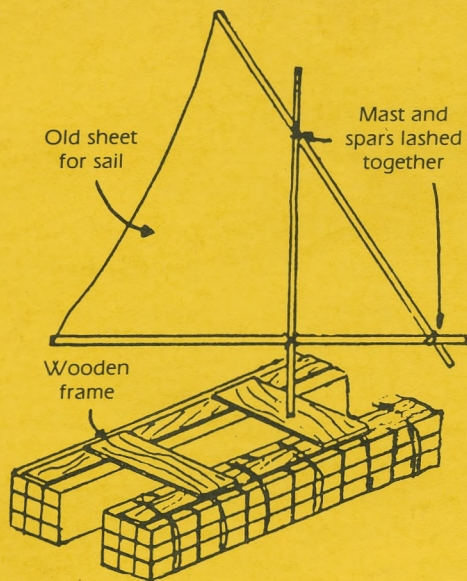

1. Catamaran Sailboat or Paddle Boat

Two pontoons constructed of bundles of cartons lashed to a frame support sailer. Add mast if entering race No. 4. Mast should be braced with rope "stays" tied to corners of the frame.

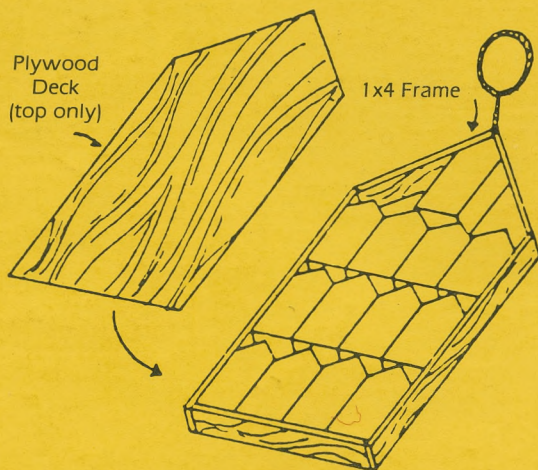

2. Basic Design

A standard boat design with pointed bow. Frame made of 1"x4" or similar lumber forms sides. Plywood deck covers frame and cartons. Cartons are glued to underside of deck to furnish flotation. May be equipped with oars or sail.

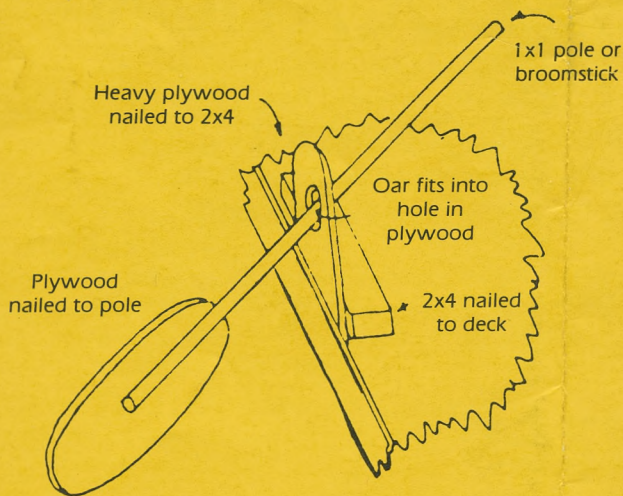

4. Oar and Oar Lock

Properly designed oars will help propel your boat at maximum speed. Check lengths of handles for comfortable fit to you and to your boat.

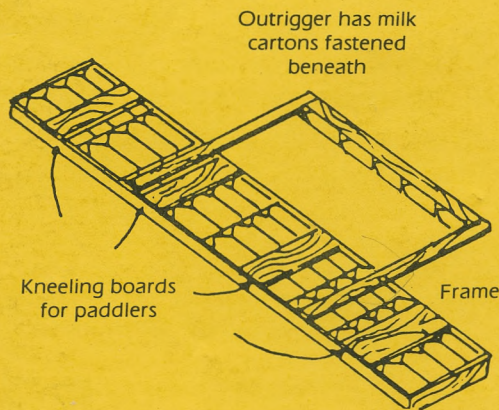

3. Outrigger

A long, slim design for several paddlers. Cartons are glued to frame or lashed into position. The outrigger minimizes tipping. Alternate design without the outrigger could be a rowing shell.